

A Review on Thermodynamic Performance Analysis of A Cascade Refrigeration System for Refrigerant Couples of R22/R404a, And R744/R404a

M. Tech. Scholar Abdul hakim¹

Department Mechanical Engineering
School of Engineering and Technology
Madhyanchal Professional University Bhopal
Abdul001mpu@gmail.com

Asst. Prof. Praveen kumar kushwaha²

Department of Mechanical Engineering
School of Engineering and Technology
Madhyanchal Professional University Bhopal
Praveenkumarkushwaha95@gmail.com

Abstract - The study of cascade refrigeration system. Cascade refrigeration system is the combination of two refrigeration cycle for maximum refrigeration effect can be obtained. In this system series of single stage vapor compression system are thermally coupled with the evaporator of HTC and condenser of LTC, this combination is known as cascade. This system is developed to achieve temperature up to -20°C for the applications like cold storage in malls and stores and in blood banks. The working fluid in system are R22 (LTC) and R134a (HTC), these particular refrigerant s are used due there suitable difference in boiling point for the desirable outcome from the system. These fluids are harmless to environment and GWP and ODP is negligible and do not violate the kyoto protocol. COP, work done, Refrigeration effect are the parameters studied from the system.

Keywords: Cascade refrigeration system, R22/R404a, AND R744/R404a

I. INTRODUCTION

Refrigeration and air conditioning (RAC) play a very important role in modern human life for cooling and heating requirements. This area covers a wide range of applications starting from food preservation to improving the thermal and hence living standards of people. The utilization of these equipment's in homes, buildings, vehicles and industries provides for thermal comfort in living/working environment and hence plays a very important in increased industrial production of any country. Due to the increasing demand of energy primarily for RAC & HP applications (around 26-30%) this leads to degradation of environment, global warming and depletion of ozone layer etc., to overcome these aspects there is urgent need of efficient energy utilization besides waste heat recovery for useful applications especially after the Kyoto and Montreal protocols. The scientific community is eagerly concentrating on the alternate and environment friendly refrigerants, especially after the Kyoto and the Montreal protocols. However, in a quest to find out the alternate and environment friendly refrigerants, the energy efficiency of this equipment's while using conventional refrigerants is also very important. The CFCs and HCFCs remain as refrigerant fluids of choice for various applications for many years and now non-ozone depleting HFCs became favored. The Montreal protocol banned production and consumption of ozone depleting compounds in 1987 and also accelerated the rate of phasing out of CFC and HCFC in order to reduce ozone depletion, and this was only possible by

using HFCs in many applications. The Kyoto protocol laid down goals for the reduction of global warming substances in the year 1997 and subsequently the heat pump industry has consequently been forced to look for substitutes of CFCs and HCFCs. In many applications hydrocarbons have been used but this has been limited by safety considerations. Energy saving and climate change is the outcome of system design, which includes the selection of refrigeration cycle, the working fluid (refrigerant), and the minimization of refrigerant quantity and leakage. It also relates to the installation, the service procedures, and the improvement of energy efficiency to reduce the direct emissions of carbon dioxide into the atmosphere.

II. LITERATURE REVIEW

In Canaan Cimsit (2018) study, the absorption part has been designed to improve the performance of absorption – vapor compression cascade cycle as serial flow double effect. The detailed thermodynamic analysis has been made of double effect absorption –vapor compression cascade refrigeration cycle. For the novel cycle working fluid used R-134a for vapor compression section & LiBr-H₂O for absorption section. This cycle has been compared with single effect absorption – vapour compression cascade cycle & one stage vapour compression refrigeration cycle. The results indicate that the electrical energy consumption in the novel cycle is 73% lower than the one stage vapor compression refrigeration cycle. Also the therma energy consumption

in the cascade cycle is 38% lower than the single effect absorption–vapor compression cascade refrigeration cycle. It is found that the minimum & maximum exergy efficiency occurs in the cooling set & low pressure generator (LPG) as 21.85% & 99.58% respectively.

Gaudy Prada Botia (2018) document presents a combined refrigeration system consisting of two vapor compression refrigeration cycles linked by a heat exchanger that not only reduces the work of the compressor but also increases the amount of heat absorbed by the refrigerated space as a result of the cascade stages & improves the COP of a refrigeration system.

Jinkun Zhou et al (2018) find out that waste heat can be utilized in absorption refrigeration systems. In this article, the performance of an auto-cascade absorption refrigeration system using R23/R134a/DMF solutions as the working substance was analyzed. Optimization analysis results showed that to some extent, the COP could be increased when the low pressure of the system decreased. The reasonable upper limit of the high pressure was the high pressure at the turning point of COP, and the reasonable lower limit of the low pressure was the low pressure at the turning point of COP. The COP of the system monotonously increased with the increase of the mole fraction of R23 in solutions. The low R23 mole fractions were more appropriate.

R.S. Mishra (2017) deals with thermodynamic analysis of three stages cascade vapor compression refrigeration systems using eco-friendly refrigerants used for low temperature applications. The effect of thermal performance parameters on the first law thermal performances COP system and also in terms of second law efficiency of the cascade system and System exergy destruction ratio have been optimized thermodynamically using entropy generation principle. The utility of R1234ze and R1234yf and in the high temperature circuits and new eco-friendly refrigerants in the intermediates circuits and R134a or R404a in the low temperature cascade circuit have been optimized. It was observed that in the low temperature (between -50oC to -100oC) applications. It was observed that the best combination in terms of R1234ze-R134a-R404a gives better thermal performance than using R1234yf-R134a-R404a. Similarly other combination in terms of R1234ze-R134a-R404a gives better thermal performance than using R1234ze-R1234yf-R404a.

Umesh C. Rajmane (2017) study is presented a cascade refrigeration system using as refrigerant (R23) in low temperature circuit and R404a in high temperature circuit. The operating parameters considered in this paper include superheating, condensing, evaporating and sub cooling temperatures in the refrigerant (R404a) high temperature circuit and in the refrigerant (R23) low temperature circuit.

Manoj Dixit et al (2016) study helps to find out the best refrigerants and appropriate operation parameters. It is

found in the study that cascade condenser, compressor and refrigerant throttle valve are the major source of exergy destruction. The analysis has been realized by means of mathematical model of the refrigeration system.

Umesh C. Rajmane (2016) study provides the advantages of vapour compression refrigeration system & also summaries various techniques used in cascade refrigeration system. The operating parameters considered in this study include Condensing , Sub Cooling, Evaporating & Super heating temperatures in high – temperature circuit & temperature difference in Cascade heat exchanger Evaporating, Superheating, condensing & Sub-cooling in the low temperature circuit.

Bhavesht Patel, Surendra Singh Kushwaha (2016) introduces a new concept of Two Stage Vapor Compression-Absorption Cascade Refrigeration System (TSVCACRS) for achieving low temperature Industrial Cooling. The system comprises of Two Stage Vapor Compression System having flash intercooler integrated with single stage vapor absorption refrigeration system, thermally coupled by means of cascade condenser heat exchanger. That proposed TSVCACRS system would minimize the compressor works up to 28%, compared to existing installed TSVCACRS.

Gami et.al. (2014) reported a thermodynamic energy and exergy analysis cascade refrigeration system using refrigerants pairs R134a R23and R290-R23 is presented in this paper to optimize the operating parameters of the system. The results show that COP and exergetic efficiency decreases when degree of superheating increases in LT system and increases when degree of superheating increases in HT system and remain constant when degree of superheating increases in HT and LT system. The results show that COP and exergetic efficiency increases when degree of sub cooling increases in all three cases as discussed above.

A. D. Parekh and P. R. Tailor (2014) thermodynamic analysis of cascade refrigeration system has been done using three different refrigerant pairs R13-R12, R290-R23, and R404A-R2. Thermodynamic analysis shows that out of three refrigerant pairs R12-R13, R290-R23 and R404A-R23 the COP of R290-R23 refrigerant pair is highest.

III. CASCADE REFRIGERATION SYSTEM

The first low temperature refrigeration system was primarily developed for solidification of carbon dioxide and liquefaction & subsequent fractional distillation of gases such as air, oxygen, nitrogen, hydrogen and helium Ultra low temperature refrigeration in industrial work has increased tremendously in the last few years [2].

Cascade Process

Cascade system is just similar to the binary vapor cycle used for the power plants. In a binary vapor cycle, a

condenser for mercury works as boiler for water. Similarly in cascade system condenser of low temperature cycle works as evaporator for the high temperature cycle. In cascade system, a series of refrigerants with progressively lower freezing points are used in a series of single stage unit. The cascade condensing unit used two refrigerating systems or cycles and referred to as cycles A and B. The condenser of cycle B, called the “high stage”, is usually fan cooled or in some cases a water supply may be used to cool but air cooling is common. The Evaporator of cycle B is used to cool the condenser of cycle A called the “low stage”. The unit that consist of condenser of cycle A and evaporator of cycle B. is often referred to as the “Inter-stage condenser” or “cascade condenser”. Thus a cascade condenser serves as an evaporator “for high temperature cascade system (cycle A)”. The difference in low temperature cascade condenser temperature and high temperature cascade evaporator temperature is called temperature overlap and is necessary for heat transfer. Cascade system use two different refrigerants in each stage. The reason that two refrigeration systems are used because single stage system cannot economically achieve the high compression ratio necessary to obtain evaporating and condensing temperatures. The high temperature cascade system uses a refrigerant with low boiling temperature such as R-13 or R-13B1. These low boiling temperature refrigerants have extremely high pressure which ensures a smaller compressor displacement in the low temperature cascade system and a higher COP [2].

Another set of refrigerants commonly used for liquefaction of gases in a three stage cascade system is ammonia, ethylene and methane. The additional advantage of a cascade system over multi stage compression is that the lubricating oil from one compressor cannot wander to the other compressors. Cascade staging incorporates several individual refrigeration systems that use different refrigerants and have closed heat exchangers to achieve low operating temperatures and reasonable condensing pressure. For some industrial applications which require moderately low temp, single stage vapor compression refrigeration cycle and vapor absorption refrigeration cycle become impractical therefore cascade system are employed to obtain high temperature differentials between the heat source & heat sink. These systems are applied for temperature ranging from -70°C to -100°C [3].

Two stage cascade refrigeration system is represented by a P-h diagram in Fig.1.1 and 1.2 respectively. In the system both Low Temperature Cycle (LTC) and High Temperature Cycle (HTC) work with different refrigerants and thermally connected to each other through a heat exchanger which acts as an evaporator for the HTC and a condenser for the LTC. HTC operates with refrigerant having high boiling point and high critical temperature and LTC operates with refrigerant having low boiling point. Properties of refrigerants are given in

Table I. Fig.1 shows that the condenser rejects heat QHT from the condenser at condensing temperature of T_c to its condensing medium or environment. The useful refrigerating effect is produce in evaporator of LTC by absorbing the cooling load QLT from the cooling space at the evaporating temperature T_e . Heat absorbed by LTC evaporator and work input to LTC compressor equals the heat absorbed by HTC evaporator that is cascade condenser. $T_{c,cas}$ and $T_{e,cas}$ represent the condensing and evaporating temperatures respectively. The temperature difference between them, $\Delta T = T_{c,cas} - T_{e,cas}$ is called temperature overlap which is necessary for heat transfer.

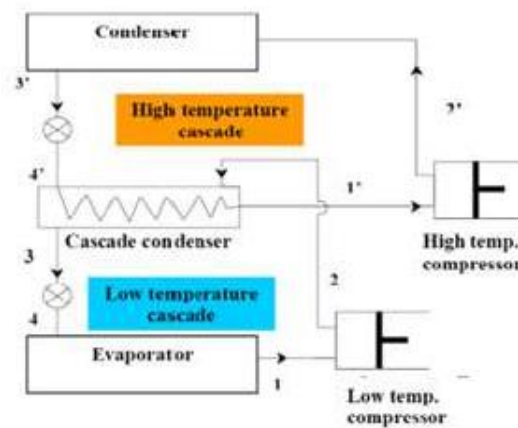

Fig. 1: Two stage cascade refrigeration system.

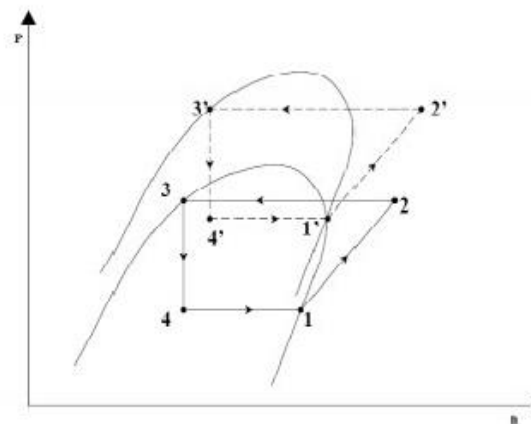

Fig. 2: P-H chart.

IV. CONCLUSION

Cascade refrigeration system is the combination of two single stage vapor compression system together; condenser of LTC and evaporator of HTC is cascaded and

forms the heat exchanger where evaporator cascade absorbs the heat from the condenser cascade which further leads to better refrigeration effect. Many industrial applications like food storage, liquefaction of petroleum vapor and natural gases precipitation of special alloys, etc. requires low temperature refrigeration in the temperature range from -30°C to -100°C [1]. In simple vapor compression system it is difficult to obtain temperature below -30°C due to poor volumetric efficiency due to high compression ratio. In cascade refrigeration system two independent refrigerants can be used selected on the basis of their suitable important properties like boiling point, critical pressure, temperature and freezing point this enhances the working of the system and increases the refrigeration effect.

REFERENCE

- [1]. Canan Cimsit, Thermodynamic Performance Analysis of the double effect absorption –vapour compression cascade refrigeration cycle. *Journal of Thermal Science and Technology*, Vol.13, NO.1 (2018).
- [2]. Leonardo Arrieta Mondragon, Guimllermo Valencia Ochoa, Gaudy Parda Botia, Computer-Aided Simulation of the Energetic and Exergetic Efficiency of a Two Stage Cascade Cooling Cycle, *International Journal of Applied Engineering Research*, ISSN: 0973-4562, Volume 13, NO. 13 (2018), pp.11123-11128.
- [3]. Jinkun Zhou, Shengjian Le, Qin Wang and Dahong Li, Optimization analyses on the performance of an auto-cascade absorption refrigeration system operating with mixed refrigerants, *International Journal of Low- Carbon Technologies* (2018), 13, 212-217.
- [4]. Umesh C. Rajmane, Cascade Refrigeration System: R404a-R23 Refrigerant, *Asian Journal of Electrical Sciences*, Vol.6, NO. 1(2017), pp. 18-22.
- [5]. R.S.Mishra, Thermal modeling of three stage vapour compression cascade refrigeration system using entropy generation principle for reducing global warming and ozone depletion using ecofriendly refrigerants for semen preservation, *International Journal of Engineering and Innovation*, vol.1, issue 2 (2017), 22-28.
- [6]. Umesh C.Rajmane, A Review of Vapour Compression Cascade Refrigeration System, *Asian Journal of Engineering and Applied Technology*, Vol.5 No.2, (2016), pp.36-39.
- [7]. Bhavesh Patel, Surendra Singh Kushwaha and Bhumik Modi, Thermodynamic modeling & parametric study of a Two Stage Compression – Absorption Refrigeration System for Ice Cream Hardening Plant. *International Conference on recent advancements in Air conditioning & Refrigeration*, Bhubaneswar, India, 10-12 Nov (2016).
- [8]. Manoj Dixit, S.C. Kaushik, Akilesh Arrora, Energy & Exergy Analysis of Absorption – Compression Cascade refrigeration system, *Journal of Thermal Engg.* 5(2016), pp 995-1006.
- [9]. J .Alberto Dopazo, Jose Fernandez-Seara-Theoretical analysis of a CO₂-NH₃ Cascade refrigeration system for cooling applications at low temperature, *Applied thermal engineering* 29 (2009) 1577-1583.
- [10]. J. Fernandez, Vapour compression –absorption cascade refrigeration system, *Applied Thermal engineering* 26(2006) 502-512.